

单位：mm

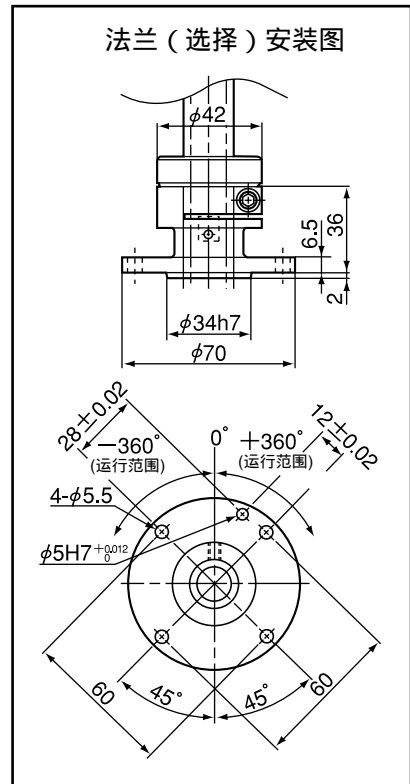
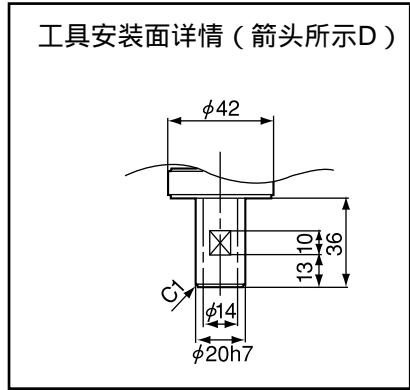
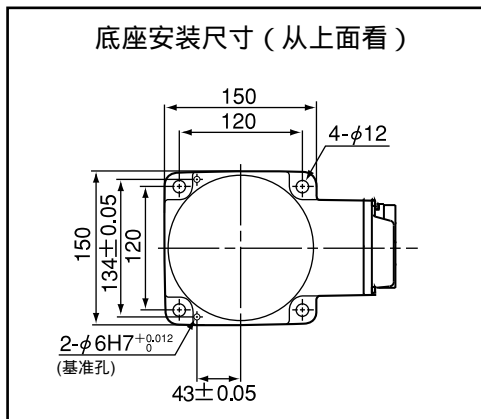

型号	A	B	C
HS-4545*G-UL	450	225	136

Z轴行程: S(mm)	L1	L2
* = 2 : 200	697	46
* = 3 : 320	817	-74 (注1)

(注1) Z : 320mm的情况下，Z轴的最低下降位置达到低于底座安装面的位置。