

단위 : mm

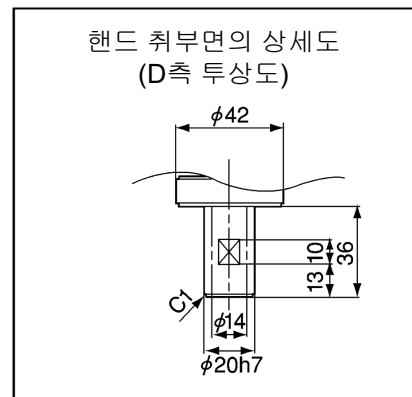
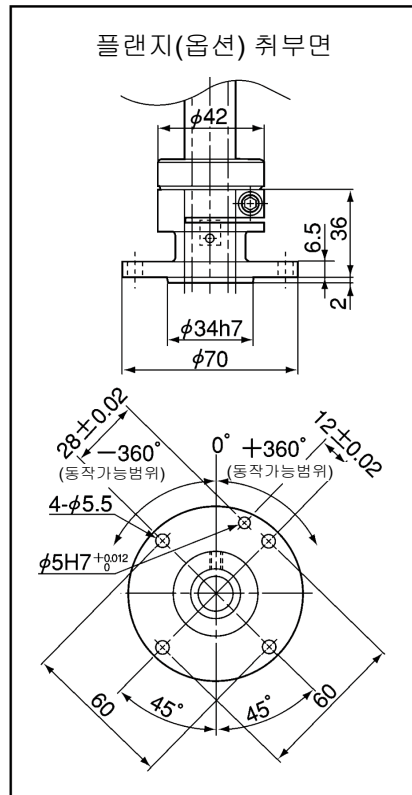

형식	A	B	C
HS-4535*G	350	125	143

Z 축 스트로크 : S(mm)	타입	L1	L2	L3
*=2 : 200	표준	697	246	46
*=3 : 320	표준	817	246	-74(주1)

주1 : Z축 스트로크가 320mm 타입의 경우 Z축의 최대하강위치가 베이스 취부면보다 낮을 수 있습니다.