

Unit : mm

Flange (Option) mounting face

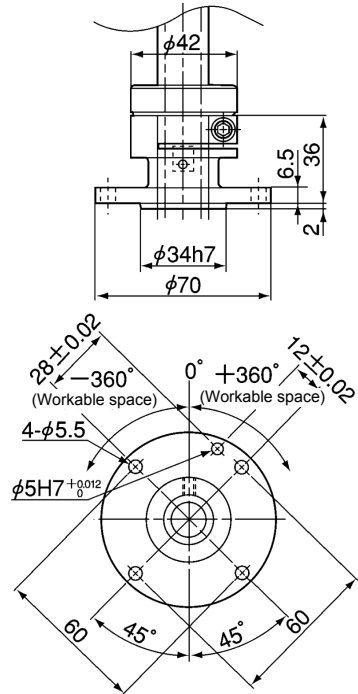

Detailed drawing of hand mounting face (Viewed from D)

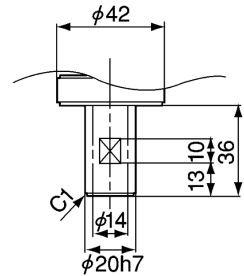

Model	A	B	C
HS-4555*G	550	325	191

Z axis stroke : S(mm)	Type	L1	L2	L3
*=2 : 200	standard	697	246	46
*=3 : 320	standard	817	246	-74(note1)

Note1 : In case of the Z axis 320mm stroke type, the Z axis in the lowermost position may reach lower than the base mounting face