

Workable space defined by point P

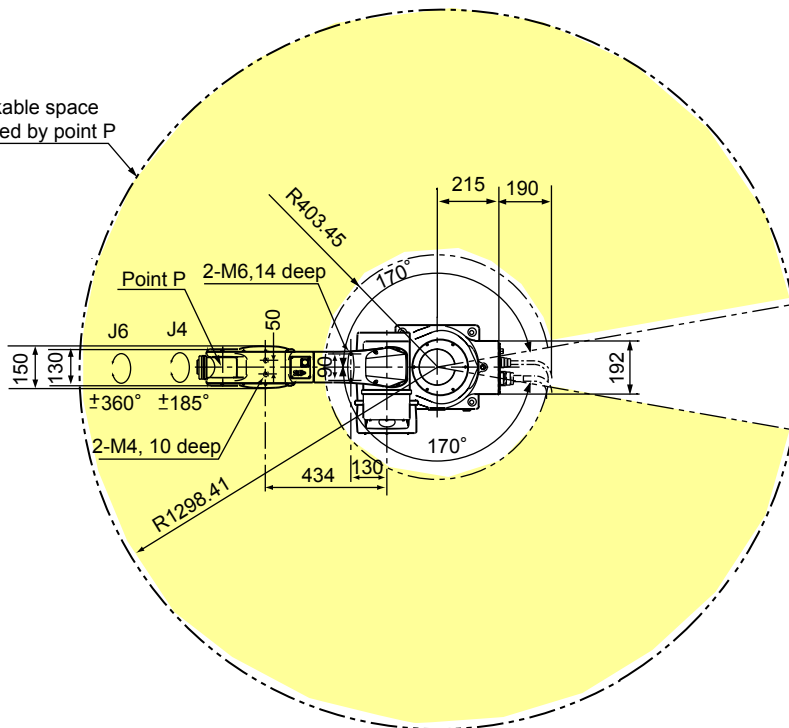

Workable space defined by point P

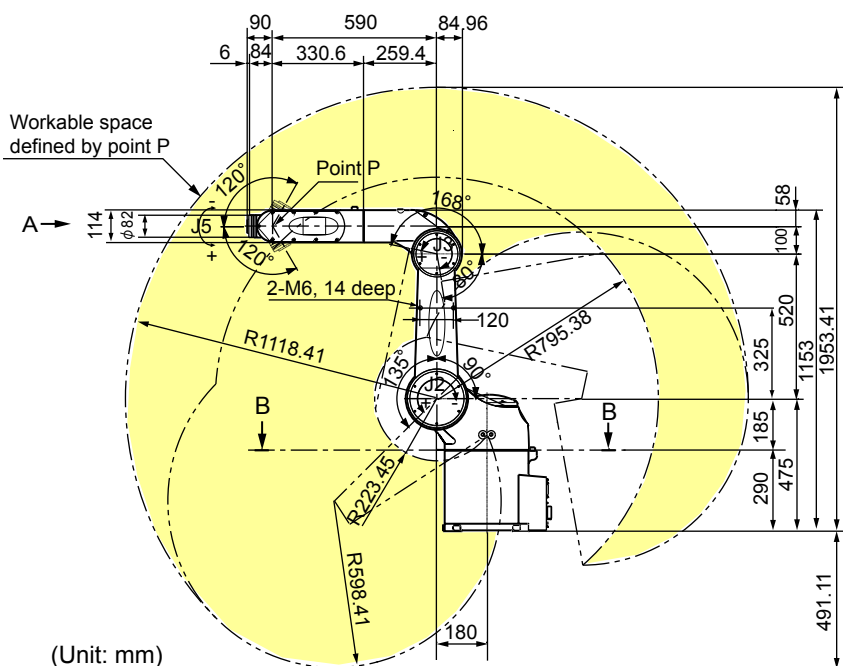

(Unit: mm)

Detailed drawing of end-effector mounting face (View: A)

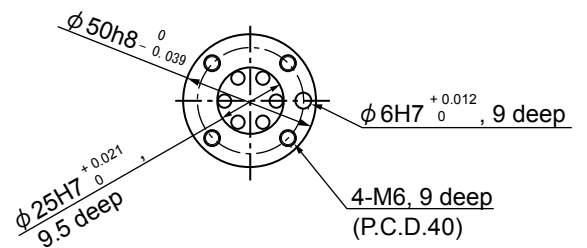

Detailed drawing of base mounting face (View: B-B)

