

Workable space defined by point P

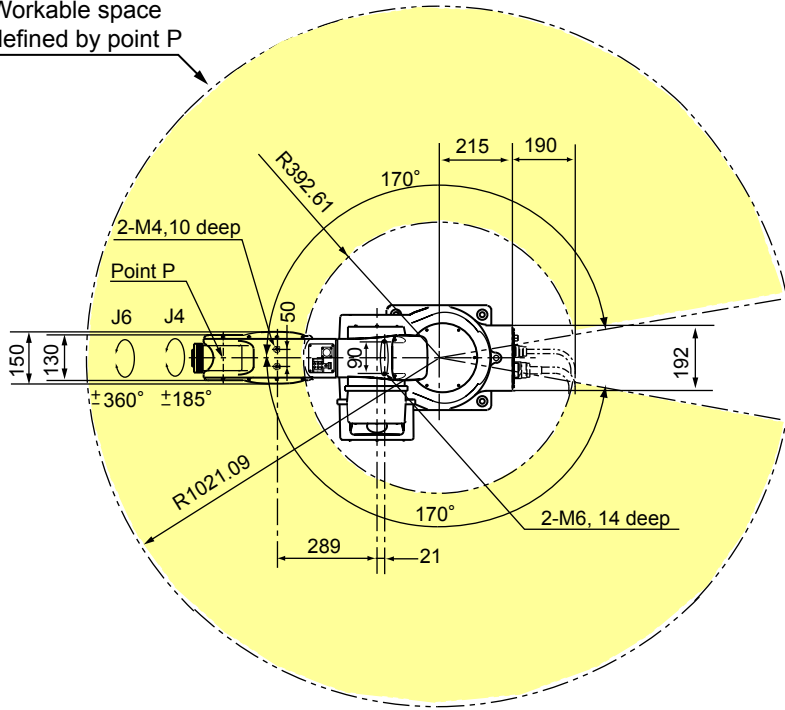

Detailed drawing of end-effector mounting face (View: A)

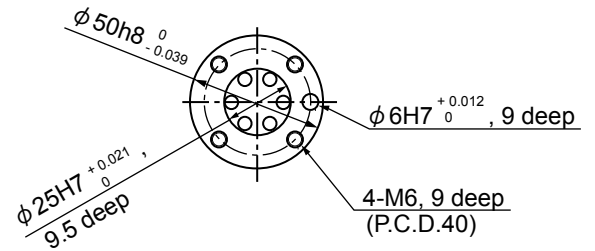

Detailed drawing of base mounting face (View: B-B)

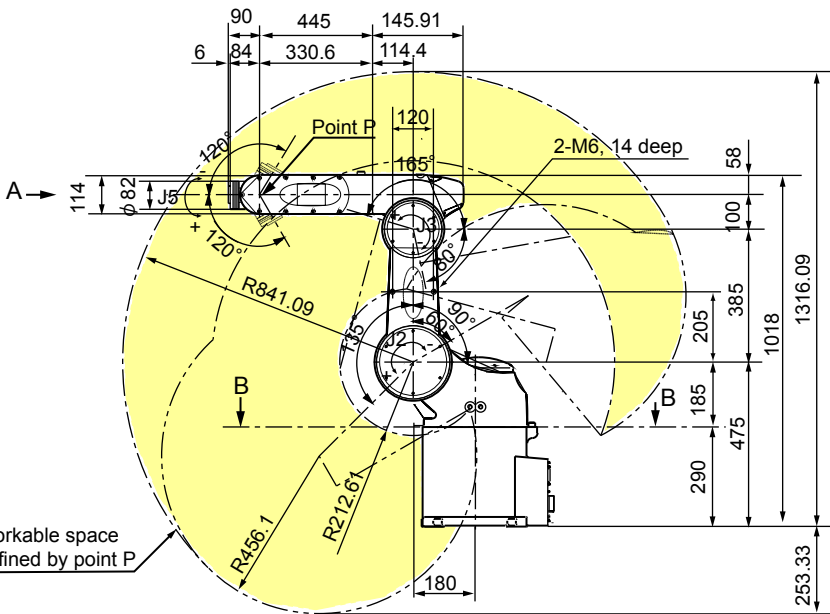
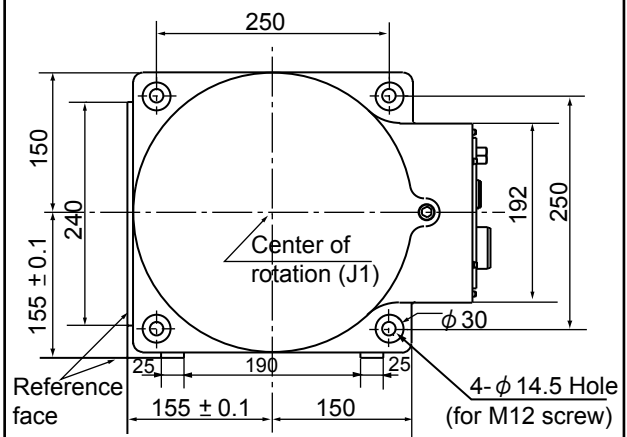

Workable space defined by point P

(Unit: mm)