

108 when Y-axis stroke is 900

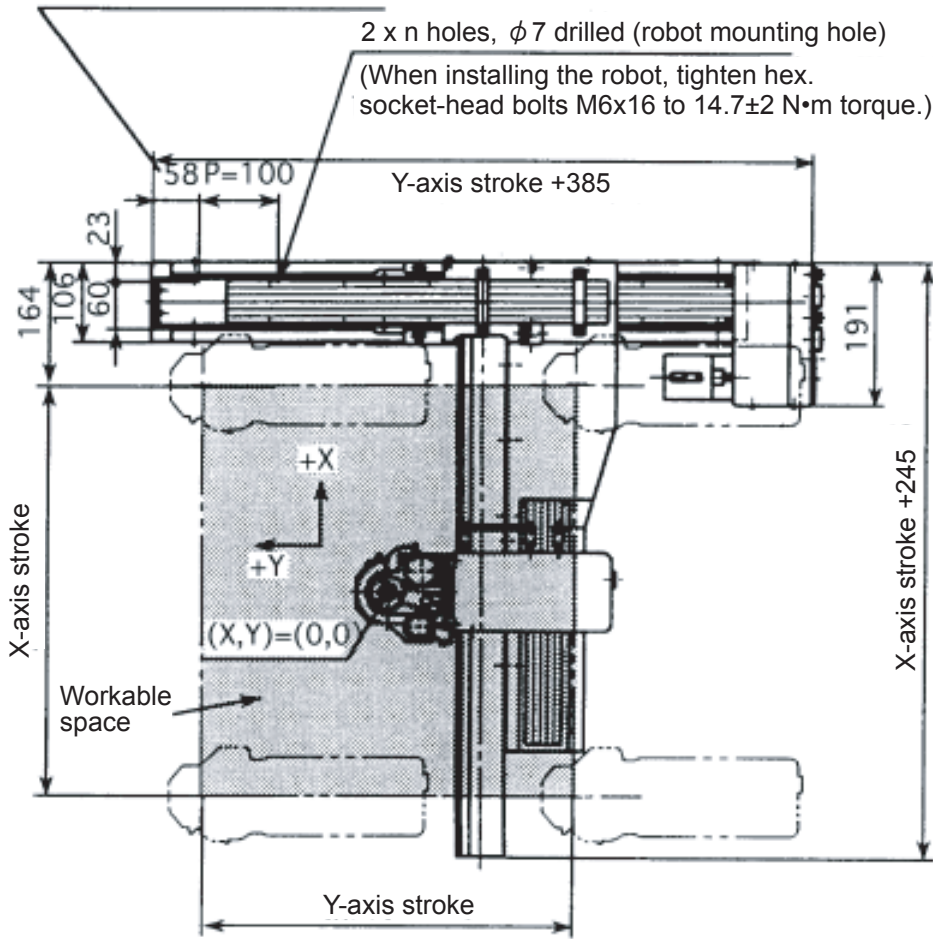

Y-axis stroke (mm)	n ↕
300↕	6↕
400↕	7↕
500↕	8↕
600↕	9↕
700↕	10↕
900↕	11↕

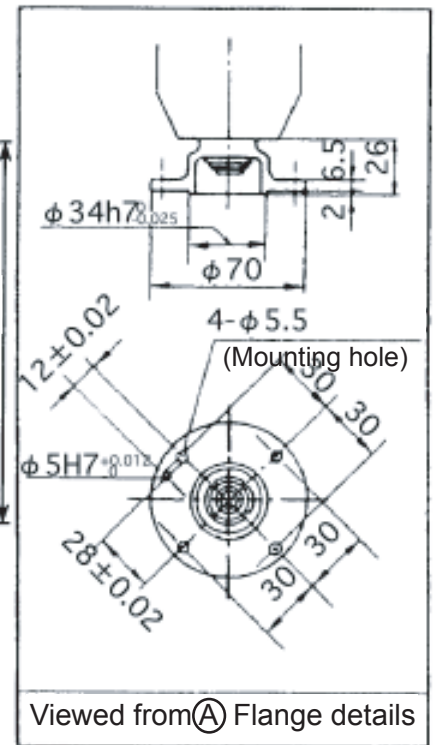
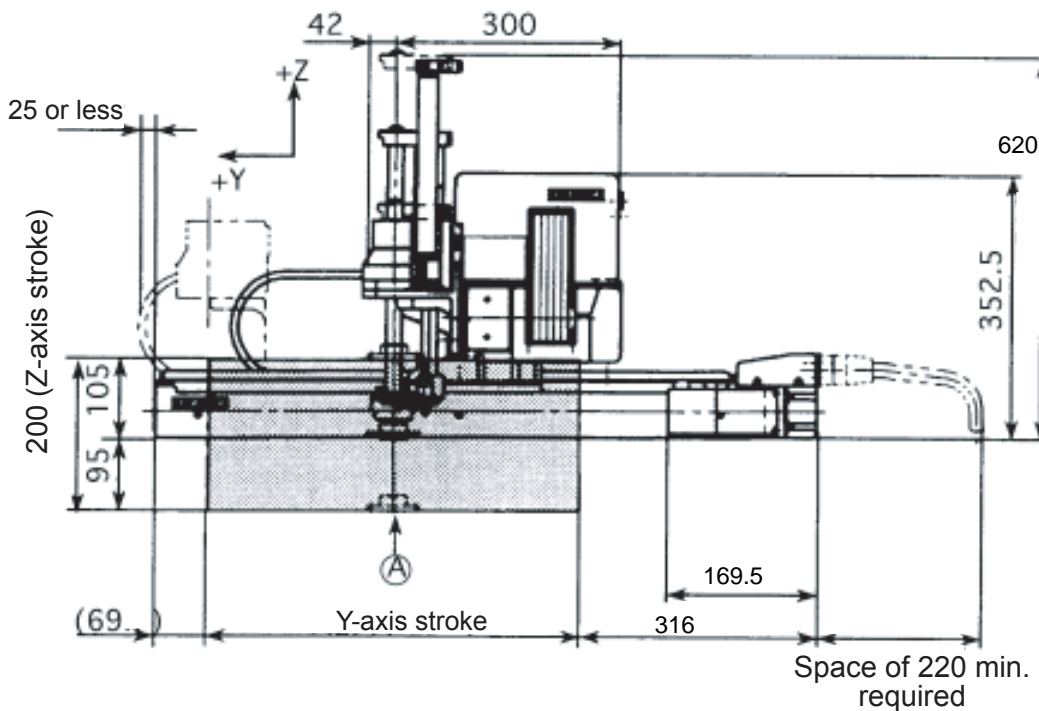

Note: The origin (X, Y, Z, T = 0, 0, 0, 0) is at the center of the X- and Y-axis strokes, at the underside of the mounting base, and at the center of the robot flange shown in "Flange details" figure.