

运行范围

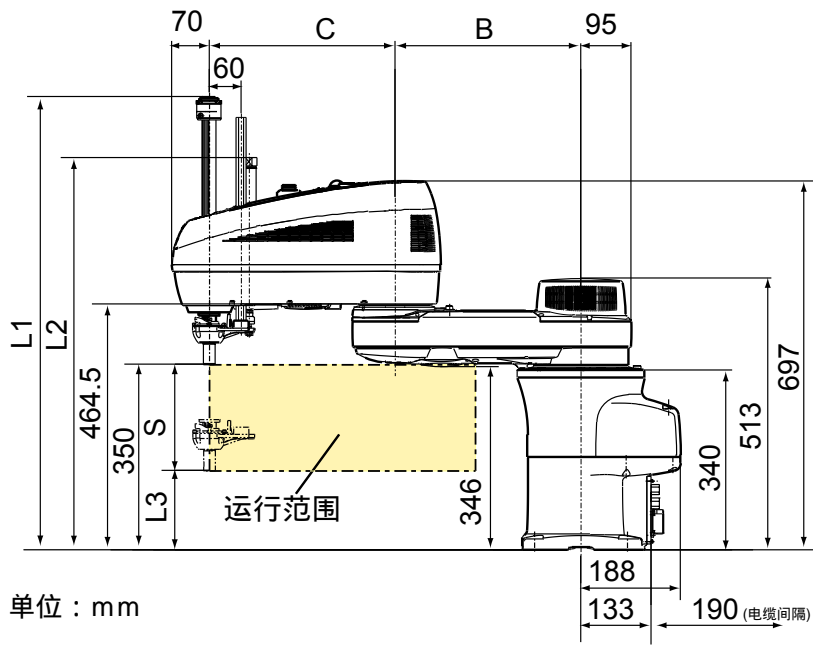

单位：mm

型号	A	B	C	D	F
HM-4A70*G-UL	700	350	350	199	294°

S (Z轴行程)	L1	L2	L3
200	849	740	150
300	949	840	50
400(注1)	1049	940	-50

(注1) Z : 400mm的情况下, Z轴的最低下降位置达到低于底座安装面的位置。

