

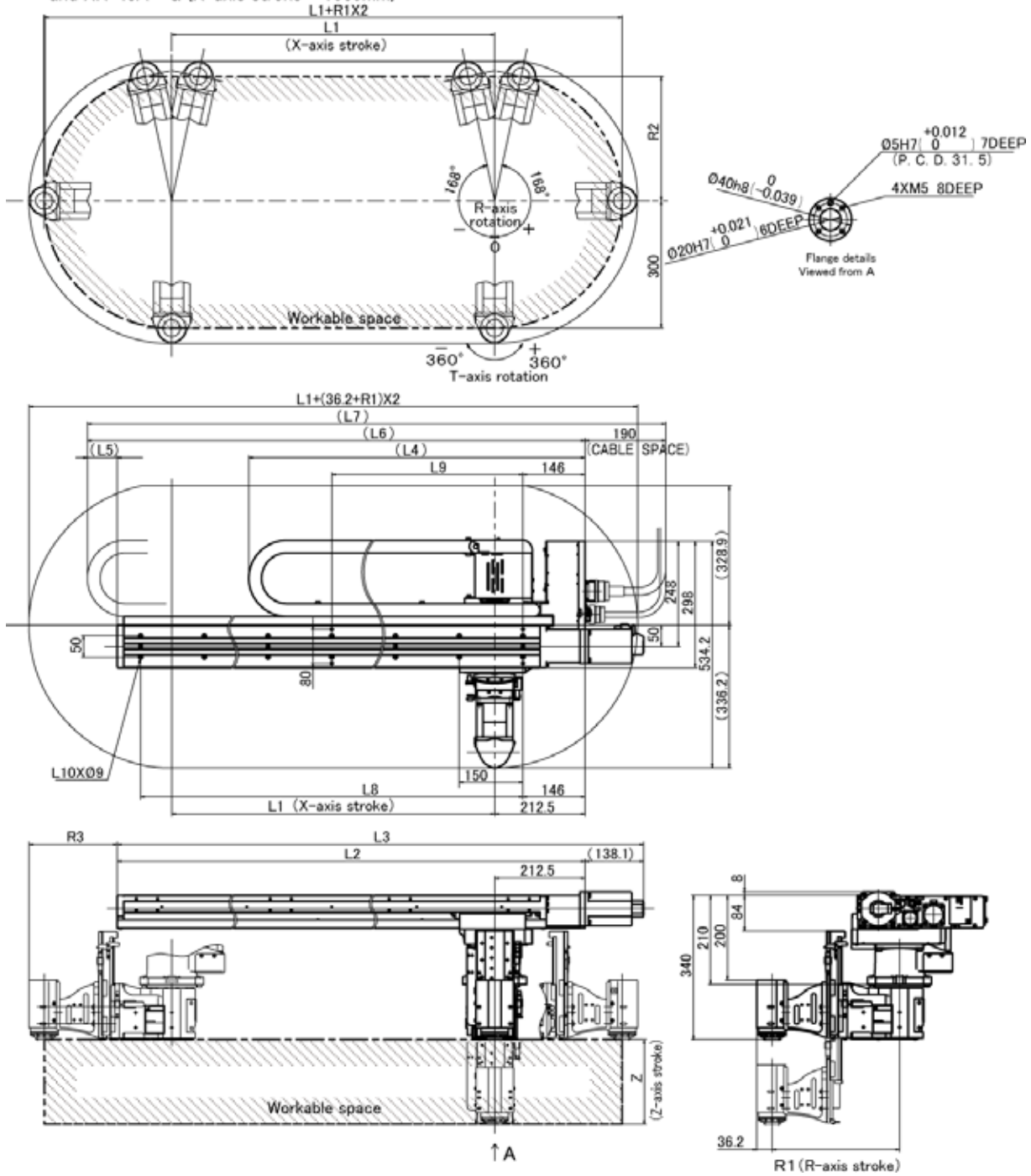

■ Outer Dimensions and Workable Space of the XR-437\*\*G (X-axis stroke = 760mm) and XR-43A\*\*G (X-axis stroke = 1060mm)



(mm)

L1(X-axis stroke)	Model	L2	L3	L4	L5	L6	L7	L8	L9	L10
760	XR-437**GM	1101	1239.1	791.2	70.2	1171.2	1361.2	6X150=900	450	14
1060	XR-43A**GM	1401	1539.1	913.7	42.7	1443.7	1633.7	8X150=1200	600	18

R1(R-axis arm length)	Model	R2	R3
200	XR-43*1*GM	195.6	107.7
250	XR-43*2*GM	244.6	157.7
300	XR-43*3*GM	293.4	207.7

Z(Z-axis stroke)	Model
135	XR-43**1GM
200	XR-43**2GM