

Workable space

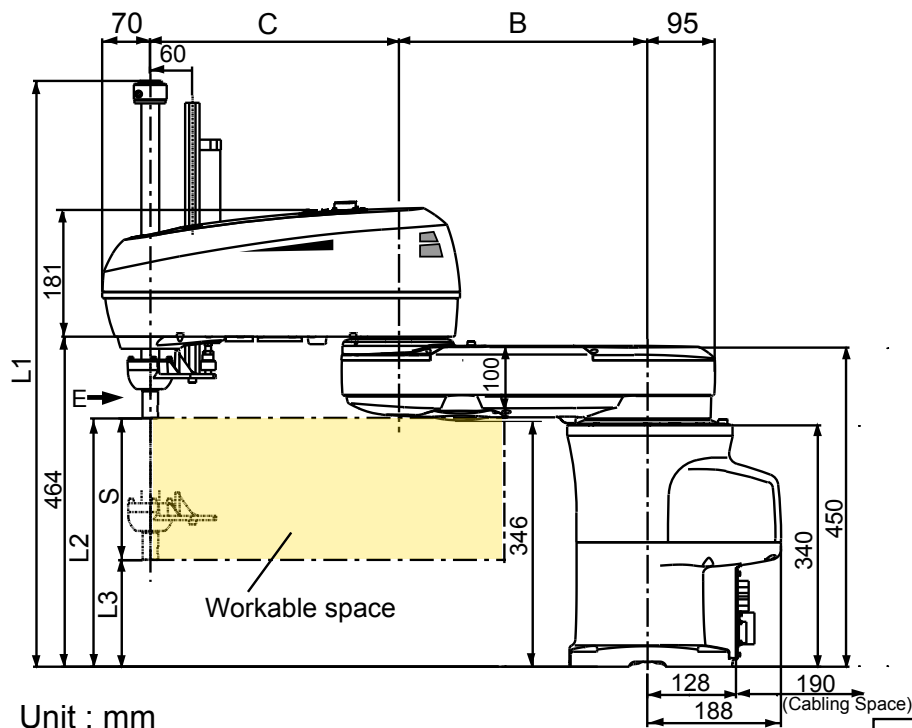

Unit : mm

Model	A	B	C	D	F
HM-4A85*G	850	350	500	281	294°

S (Z axis stroke)	L1	L2	L3
100	748.7	350	150
150	798.7	350	250
200	849	350	150
300	949	350	50
400(Note1)	1049	350	-50

Note1 : In case of the Z axis 400mm stroke type, the Z axis in the lowermost position may reach lower than the base mounting face.

