

Workable space

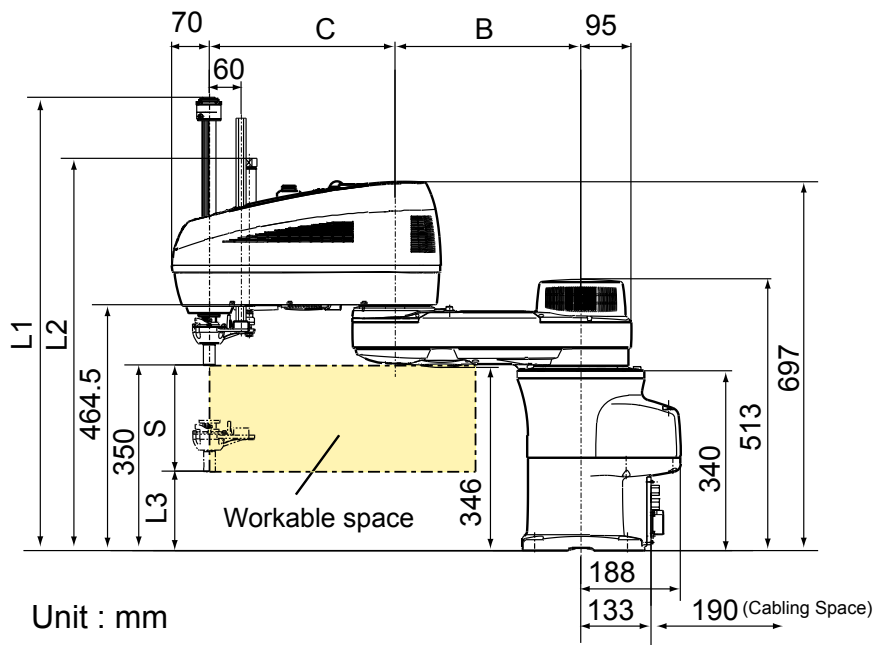

Unit : mm

Model	A	B	C	D	F
HM-4060*G-UL	600	250	350	213	286°

S (Z axis stroke)	L1	L2	L3
200	855	740	150
300	955	840	50
400(Note1)	1055	940	-50

Note1 : In case of the Z axis 400mm stroke type, the Z axis in the lowermost position may reach lower than the base mounting face.

