

VM-D Series Vertical articulated robot

Robot Specifications

(1) VM-6070D (Nickname: VM900)

Item	Specifications	
	Standard type (VM)	Dust-proof & splash-proof type (VM-W)
Model name of robot set (Note 1)	VM-6070D	VM-6070D-W
Model name of robot unit	VM-6070DM	VM-6070DM-W
Overall arm length	350 (first arm) + 350 (second arm) = 700 mm	
Arm offset	J1 (swing): 150 mm, J3 (front arm): 135 mm	
Maximum workable space	R = 965 mm (end-effector mounting face) R = 875 mm (Point P: J4, J5, J6 center)	
Motion range	J1: $\pm 170^\circ$, J2: $+135^\circ, -90^\circ$, J3: $+165^\circ, -100^\circ$ J4: $\pm 185^\circ$, J5: $\pm 120^\circ$, J6: $\pm 360^\circ$	
Maximum payload	10 kg (Note that the robot can withstand more than 7 kg payload only with the wrist facing down.)	
Maximum composite speed	8100 mm/s (at the center of an end-effector mounting face)	
Position repeatability (Note 2)	In each of X, Y and Z directions: ± 0.05 mm (at the center of an end-effector mounting face)	
Maximum allowable inertia moment	Around J4 and J5: 0.25 kgm^2 Around J6: 0.055 kgm^2	
Position detection	Simplified absolute encoder	
Drive motor and brake	AC servomotors for all joints, Brakes for joints J2 to J6	
User air piping	6 systems ($\phi 4$), 3 solenoid valves (2-position, double solenoid) contained.	
User signal line	10 (for proximity sensor signals, etc.)	
Air source	Operating pressure	$1.0 \times 10^5 \text{ Pa}$ to $3.9 \times 10^5 \text{ Pa}$
	Maximum allowable pressure	$4.9 \times 10^5 \text{ Pa}$
Degree of protection	IP40	IP54 (Wrist: IP65)
Weight	Approx. 95 kg	
<p>Note 1: The model name of robot set refers to the model name of a complete set including a robot unit and robot controller.</p> <p>Note 2: Position repeatability is the value at constant ambient temperature.</p>		

(2) VM-6083D (Nickname: VM1000)

Item	Specifications	
	Standard type (VM)	Dust-proof & splash-proof type (VM-W)
Model name of robot set (Note 1)	VM-6083D	VM-6083D-W
Model name of robot unit	VM-6083DM	VM-6083DM-W
Overall arm length	385 (first arm) + 445 (second arm) = 830 mm	
Arm offset	J1 (swing): 180 mm, J3 (front arm): 100 mm	
Maximum workable space	R = 1,111 mm (end-effector mounting face) R = 1,021 mm (Point P: J4, J5, J6 center)	
Motion range	J1: $\pm 170^\circ$, J2: $+135^\circ, -90^\circ$, J3: $+165^\circ, -80^\circ$ J4: $\pm 185^\circ$, J5: $\pm 120^\circ$, J6: $\pm 360^\circ$	
Maximum payload	10 kg	
Maximum composite speed	8300 mm/s (at the center of an end-effector mounting face)	
Position repeatability (Note 2)	In each of X, Y and Z directions: ± 0.05 mm (at the center of an end-effector mounting face)	
Maximum allowable inertia moment	Around J4 and J5: 0.36 kgm^2 Around J6: 0.064 kgm^2	
Position detection	Absolute encoder	
Drive motor and brake	AC servomotors for all joints, Brakes for joints J2 to J6	
User air piping (Note 3)	7 systems ($\phi 4 \times 6, \phi 6 \times 1$), 3 solenoid valves (2-position, double solenoid) contained.	
User signal line	10 (for proximity sensor signals, etc.)	
Air source	Operating pressure	$1.0 \times 10^5 \text{ Pa}$ to $3.9 \times 10^5 \text{ Pa}$
	Maximum allowable pressure	$4.9 \times 10^5 \text{ Pa}$
Degree of protection	IP40	IP54 (Wrist: IP65)
Weight	Approx. 76 kg	Approx. 78 kg
<p>Note 1: The model name of robot set refers to the model name of a complete set including a robot unit and robot controller.</p> <p>Note 2: Position repeatability is the value at constant ambient temperature.</p> <p>Note 3: Only the $\phi 4 \times 6$ air piping system may be controlled by built-in solenoid valves.</p>		

(3) VM-60B1D (Nickname: VM1300)

Item	Specifications	
	Standard type (VM)	Dust-proof & splash-proof type (VM-W)
Model name of robot set (Note 1)	VM-60B1D	VM-60B1D-W
Model name of robot unit	VM-60B1DM	VM-60B1DM-W
Overall arm length	520 (first arm) + 590 (second arm) = 1,110 mm	
Arm offset	J1 (swing): 180 mm, J3 (front arm): 100 mm	
Maximum workable space	R = 1,388 mm (end-effector mounting face) R = 1,298 mm (Point P: J4, J5, J6 center)	
Motion range	J1: $\pm 170^\circ$, J2: $+135^\circ, -90^\circ$, J3: $+165^\circ, -80^\circ$ J4: $\pm 185^\circ$, J5: $\pm 120^\circ$, J6: $\pm 360^\circ$	
Maximum payload	10 kg	
Maximum composite speed	8300 mm/s (at the center of an end-effector mounting face)	
Position repeatability (Note 2)	In each of X, Y and Z directions: ± 0.07 mm (at the center of an end-effector mounting face)	
Maximum allowable inertia moment	Around J4 and J5: 0.36 kgm^2 Around J6: 0.064 kgm^2	
Position detection	Absolute encoder	
Drive motor and brake	AC servomotors for all joints, Brakes for joints J2 to J6	
User air piping (Note 3)	7 systems ($\phi 4 \times 6$, $\phi 6 \times 1$), 3 solenoid valves (2-position, double solenoid) contained.	
User signal line	10 (for proximity sensor signals, etc.)	
Air source	Operating pressure	$1.0 \times 10^5 \text{ Pa}$ to $3.9 \times 10^5 \text{ Pa}$
	Maximum allowable pressure	$4.9 \times 10^5 \text{ Pa}$
Degree of protection	IP40	IP54 (Wrist: IP65)
Weight	Approx. 78 kg	Approx. 80 kg
<p>Note 1: The model name of robot set refers to the model name of a complete set including a robot unit and robot controller.</p> <p>Note 2: Position repeatability is the value at constant ambient temperature.</p> <p>Note 3: Only the $\phi 4 \times 6$ air piping system may be controlled by built-in solenoid valves.</p>		

VM-D Series Vertical articulated robot

Outer Dimensions and Workable Space Defined by P [VM-6070D]

(1) VM-6070D (Standard type)

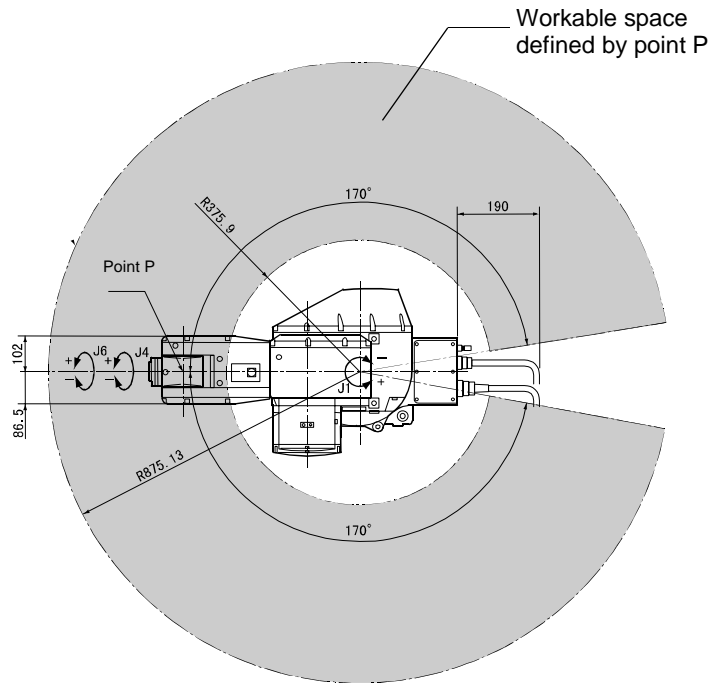

Example of nameplate (below)

Robot model

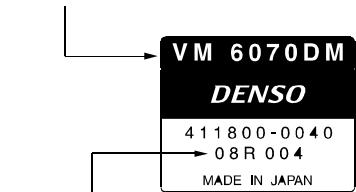

Serial number

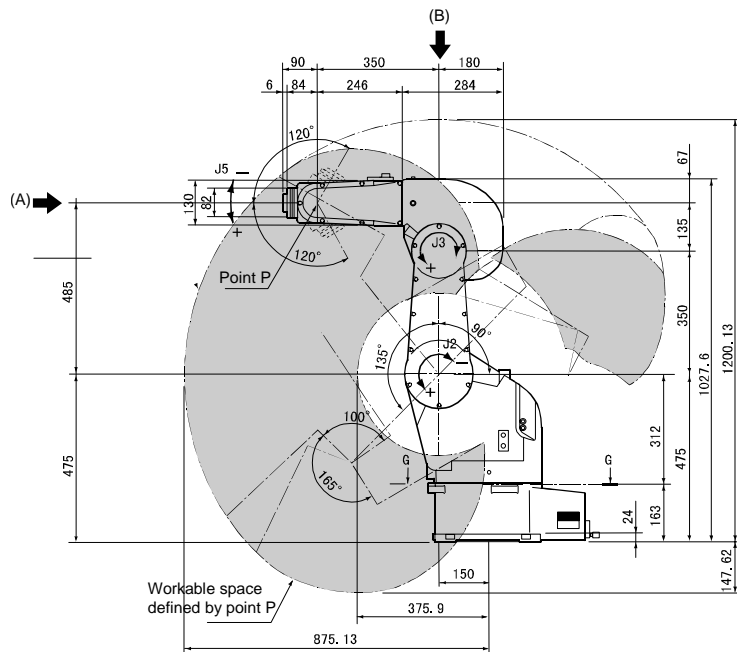

Detailed drawing of end-effector mounting face (view A)

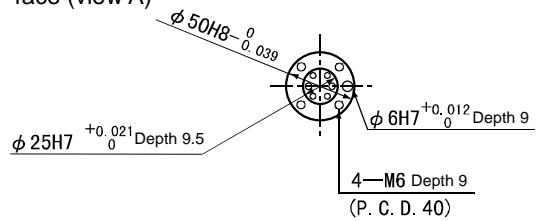

Detailed drawing of base mounting face (view B)

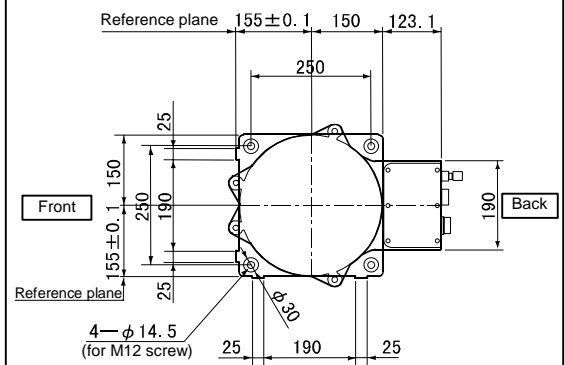

Outer Dimensions and Workable Space [VM-6070D-W]

(2) VM-6070D-W (Dust-proof & splash-proof type)

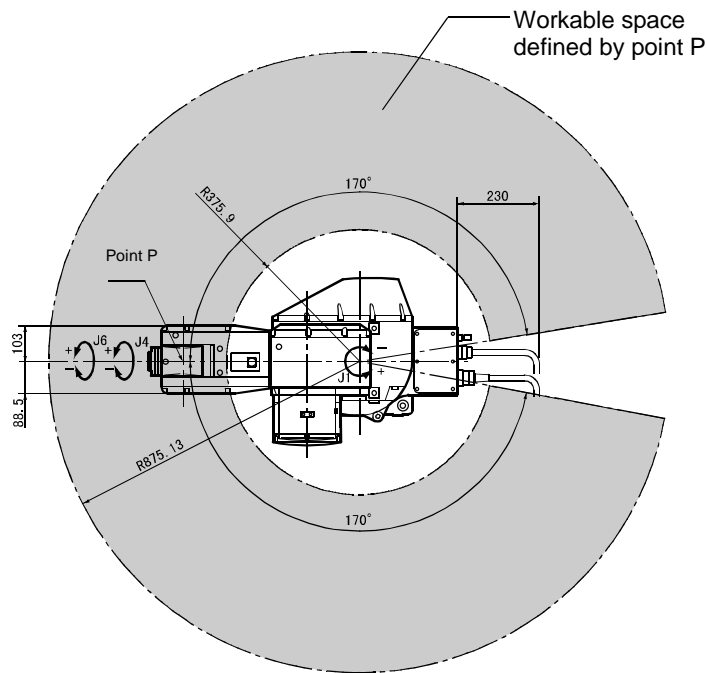

Example of nameplate (below)

Robot model



Serial number

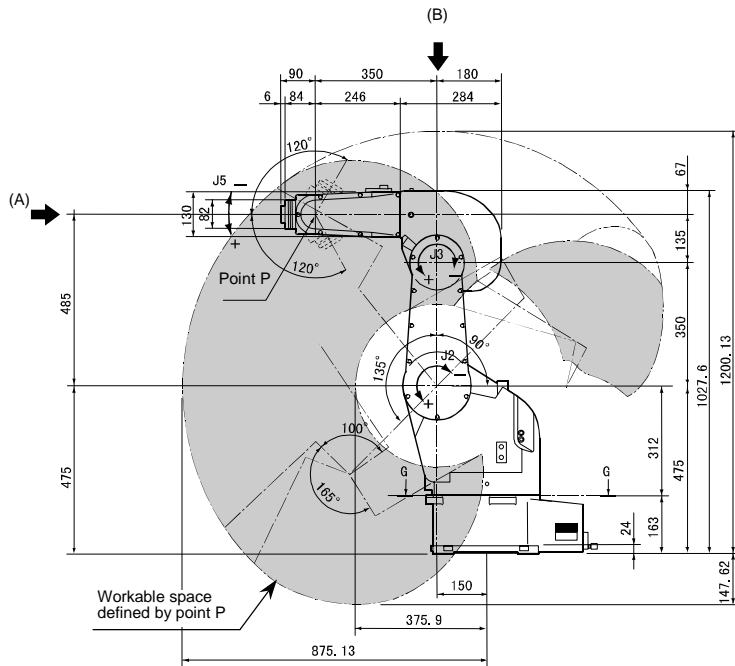

Detailed drawing of end-effector mounting face (view A)

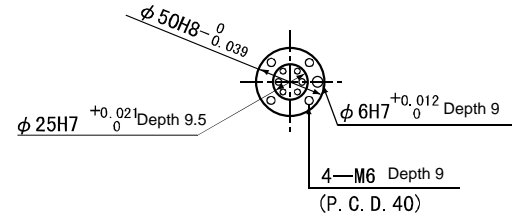

Detailed drawing of base mounting face (view B)

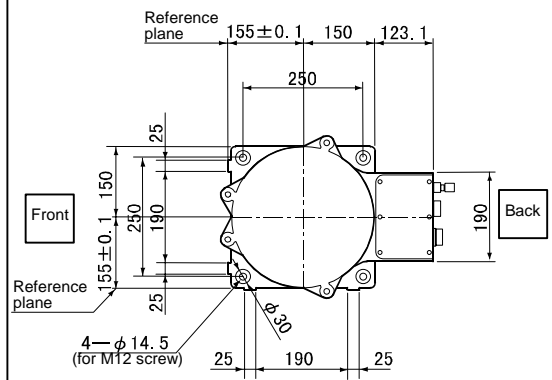

Outer Dimensions and Workable Space [VM-6083D-W]

(4) VM-6083D-W (Dust-proof & splash-proof type)

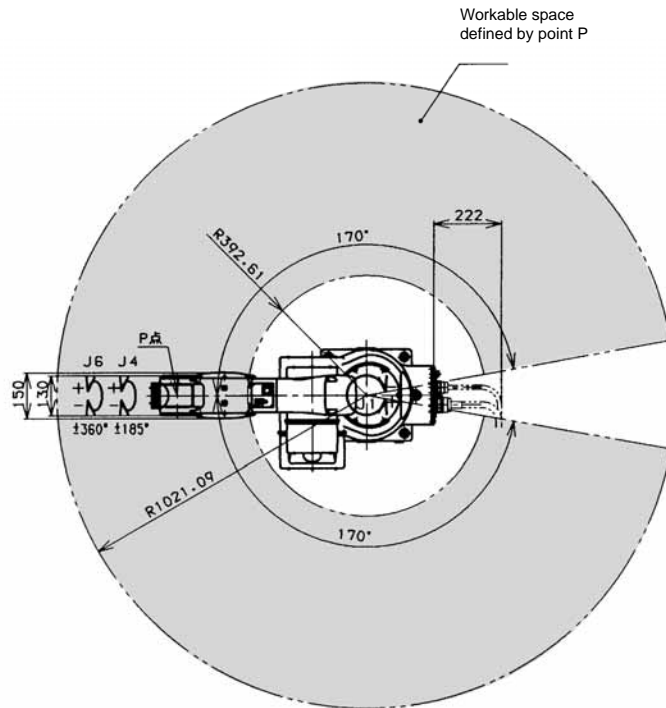

Example of nameplate (below)

Robot model



Serial number

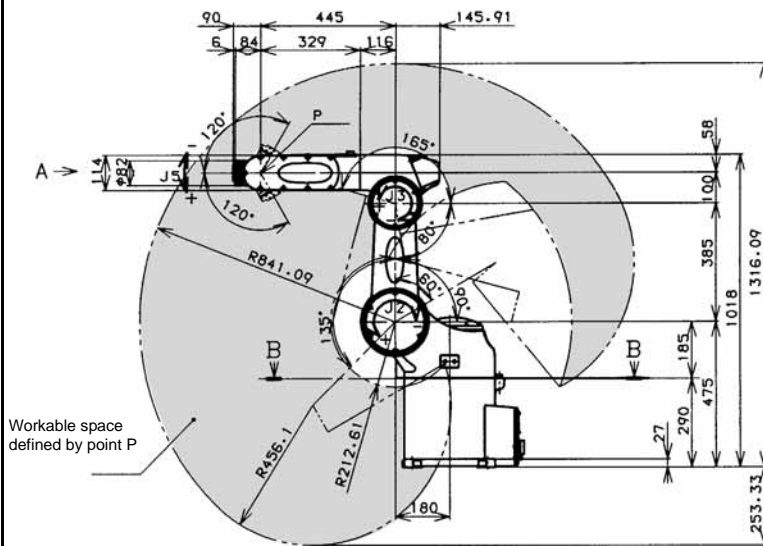

Detailed drawing of end-effector mounting face (view A)

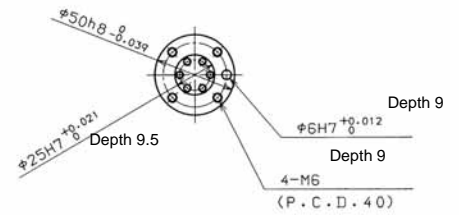

Detailed drawing of base mounting face (Sect. B-B)

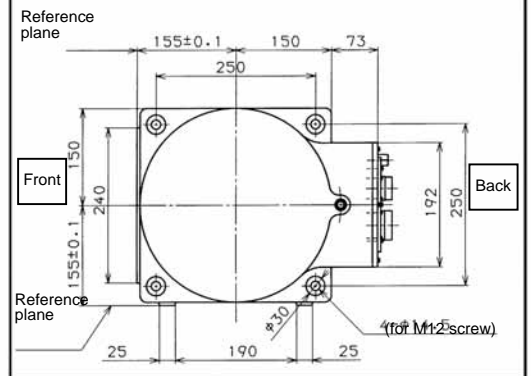

Outer Dimensions and Workable Space [VM-60B1D]

(5) VM-60B1D (Standard type)

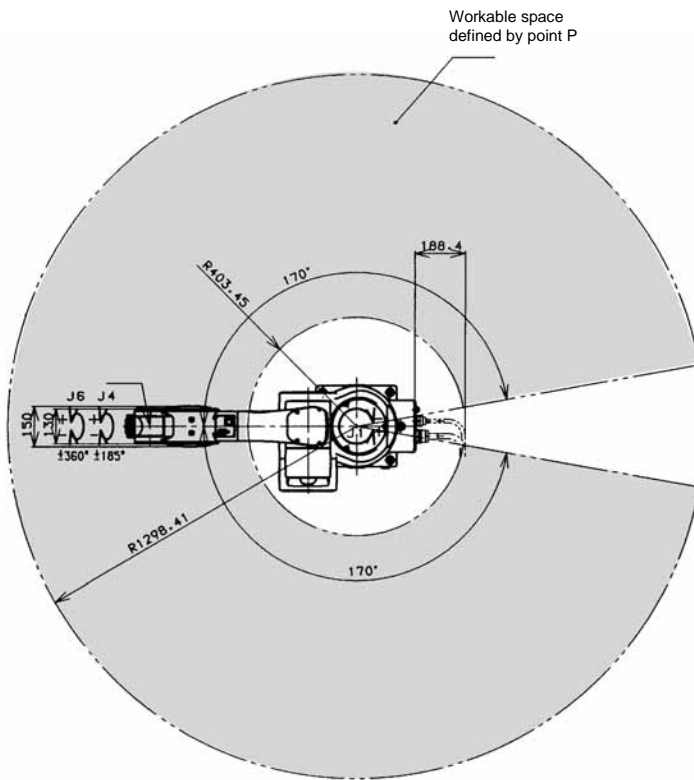

Example of nameplate (below)

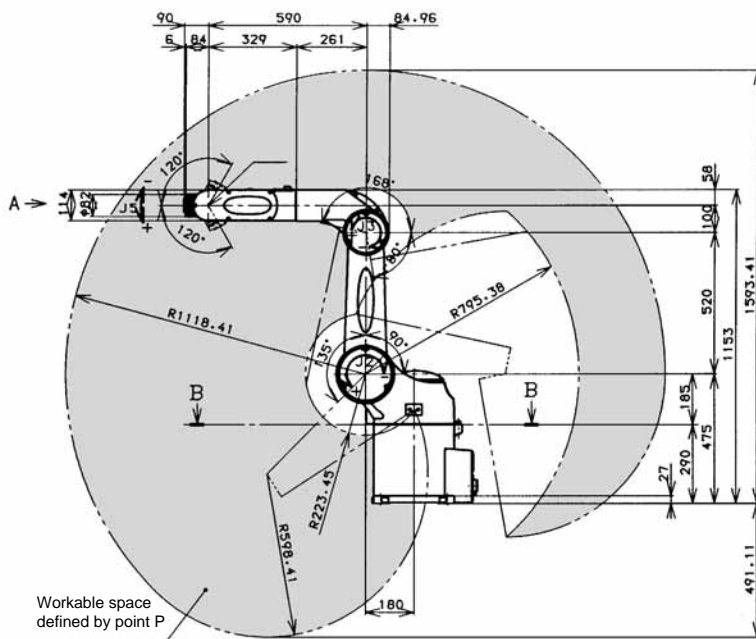
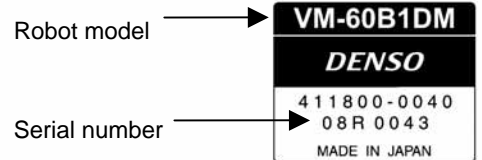

Detailed drawing of end-effector mounting face (view A)

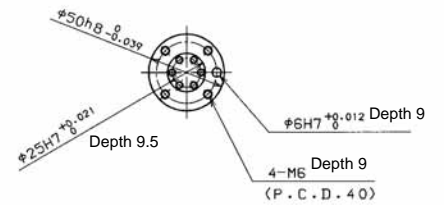

Detailed drawing of base mounting face (Sect. B-B)

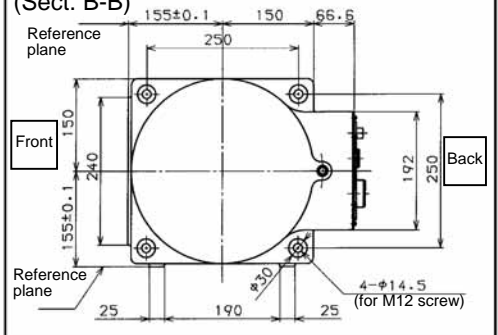

Outer Dimensions and Workable Space [VM-60B1D-W]

(6) VM-60B1D-W (Dust-proof & splash-proof type)

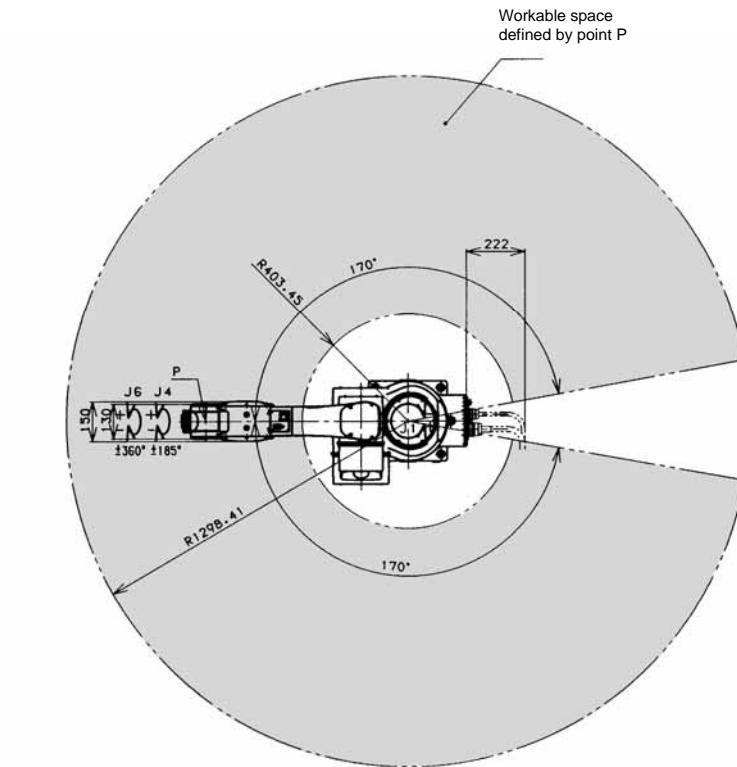

Example of nameplate (below)

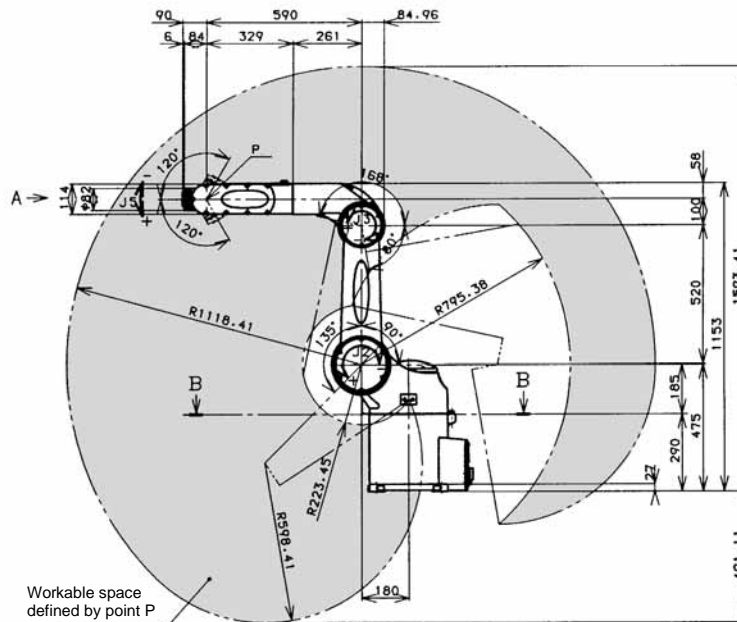
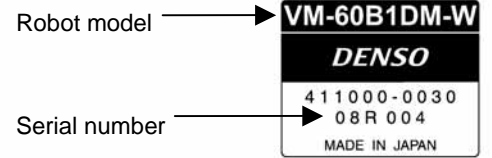

Detailed drawing of end-effector mounting face (view A)

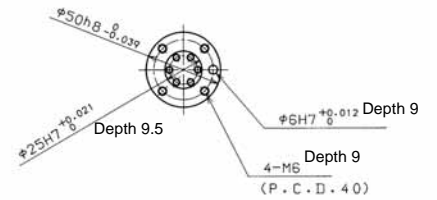

Detailed drawing of base mounting face (Sect. B-B)

